

ELECTRIC STARTER

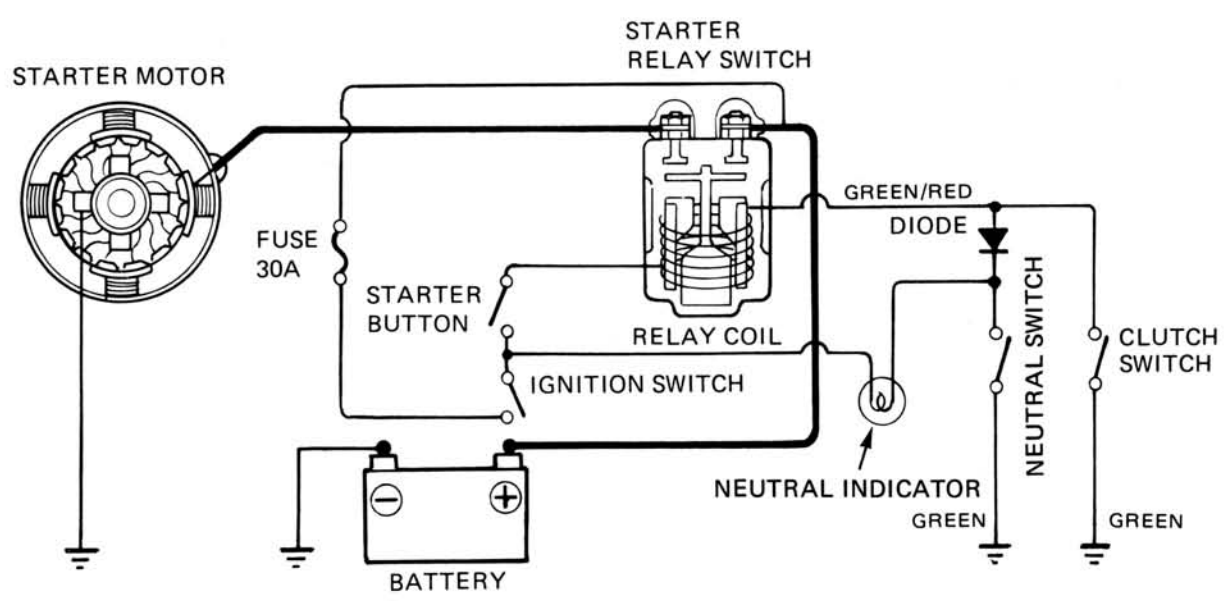
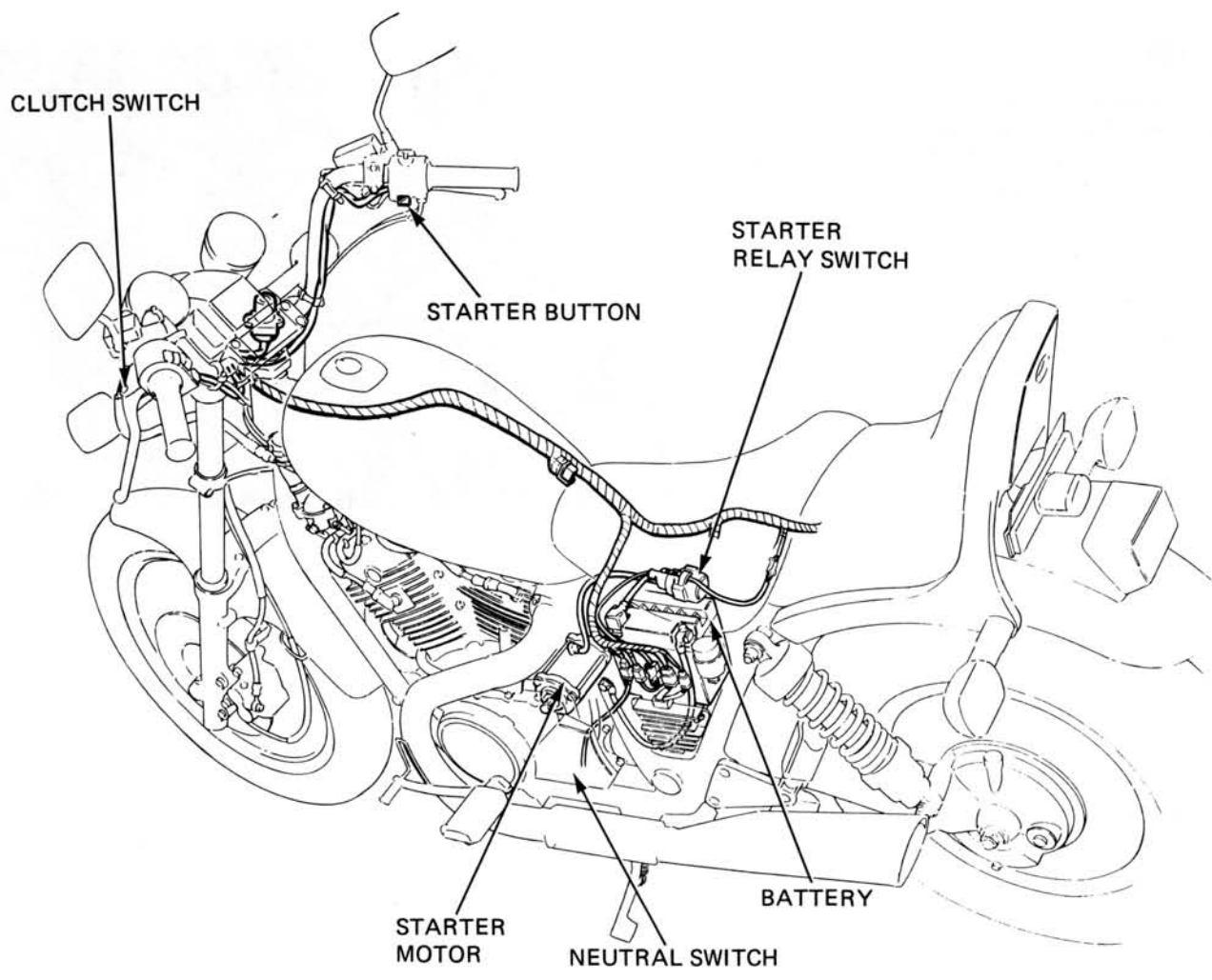

20. ELECTRIC STARTER

SERVICE INFORMATION	20-1
TROUBLESHOOTING	20-1
STARTER MOTOR	20-2
STARTER RELAY SWITCH	20-5
CLUTCH DIODE	20-5

SERVICE INFORMATION

GENERAL

- The starter motor can be removed with the engine in the frame.

SPECIFICATIONS

		STANDARD	SERVICE LIMIT
Starter motor	Brush spring tension	680-920 g (24.0-32.5 oz)	545 g (19.2 oz)
	Brush length	12.0-13.0 mm (0.47-0.51 in)	6.5 mm (0.26 in)

TROUBLESHOOTING

Starter motor will not turn

1. Battery discharged.
2. Faulty ignition switch.
3. Faulty starter switch.
4. Faulty neutral switch.
5. Faulty starter relay switch.
6. Loose or disconnected wire or cable.
7. Clutch diode open.

Starter motor turns engine slowly

1. Low specific gravity.
2. Excessive resistance in circuit.
3. Binding in starter motor.

Starter motor turns, but engine does not turn

1. Faulty starter clutch.
2. Faulty starter motor gears.
3. Faulty starter motor or idle gear.

Starter motor and engine turns, but engine does not start

1. Faulty ignition system.
2. Engine problems.
 - Low compression.
 - Fouled spark plugs.

ELECTRIC STARTER

STARTER MOTOR

REMOVAL

WARNING

With the ignition switch OFF, remove the negative cable at the battery before servicing the starter motor.

Remove the alternator cover, flywheel and starter drive gear (section 8).

Disconnect the starter motor cable at the motor. Remove the starter motor mounting bolts, and starter motor.

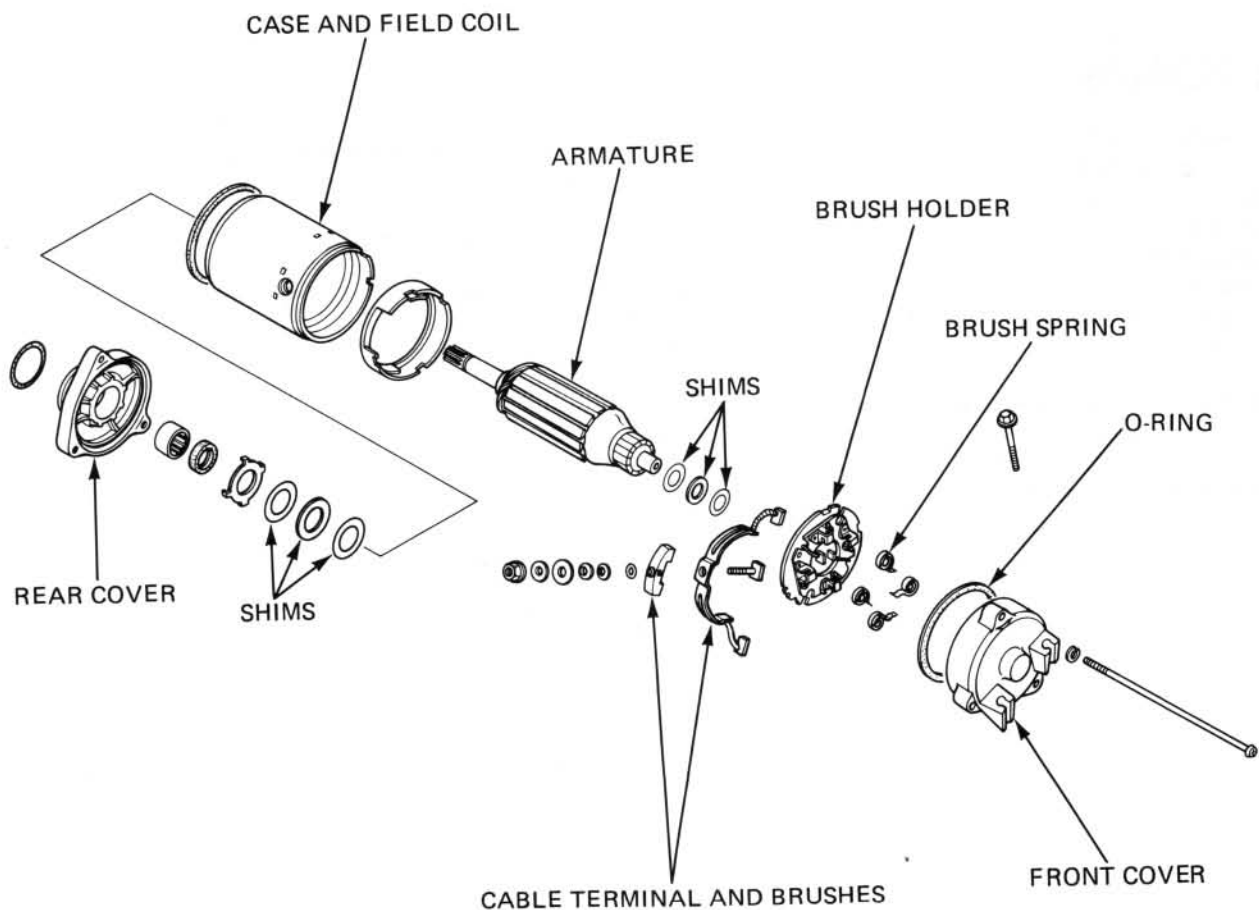
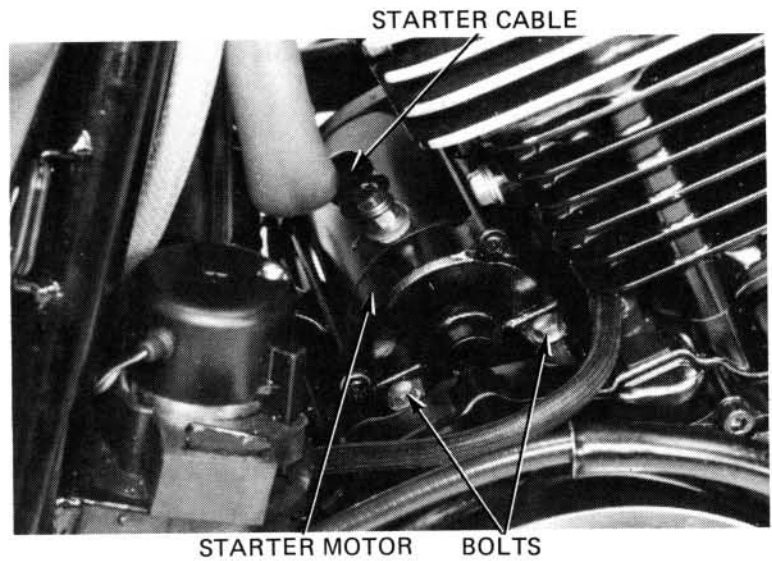

BRUSH INSPECTION

Remove the starter motor case screws.

Inspect the brushes and measure the brush length.

Measure brush spring tension with a spring scale.

SERVICE LIMITS:

Brush length: 6.5 mm (0.26 in)

Brush spring tension: 545 g (19.2 oz)

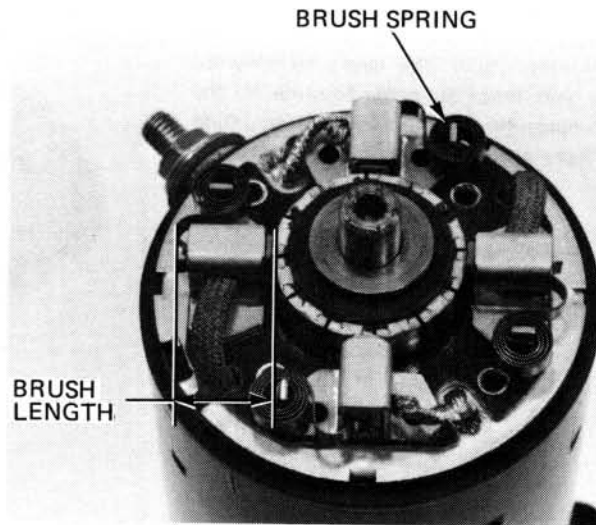

COMMUTATOR INSPECTION

Remove the starter motor case.

NOTE:

Record the location and number of thrust washers.

Inspect the commutator bars for discoloration. Bars discolored in pairs indicate grounded armature coils.

NOTE:

Do not use emery or sand paper on the commutator.

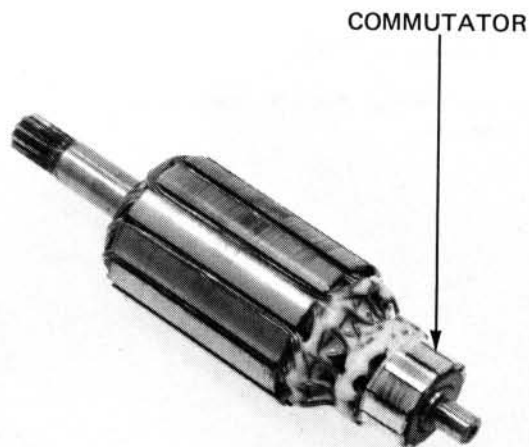

Check for continuity between pairs of commutator bars. Also, make a resistance check between individual commutator bars and the armature shaft. There should be no continuity.

**CONTINUITY BETWEEN
COMMUTATOR BAR PAIRS: NORMAL**



**NO CONTINUITY BETWEEN
COMMUTATOR BARS AND ARMATURE SHAFT: NORMAL**

ELECTRIC STARTER

FIELD COIL INSPECTION

Check for continuity from the cable terminal to the motor case and from the cable terminal to the brush wire. Replace the starter motor if the field coil does not have continuity or if it is shorted to the motor case.

NO CONTINUITY BETWEEN
CABLE TERMINAL AND MOTOR CASE: NORMAL



CONTINUITY BETWEEN
CABLE TERMINAL AND BRUSH WIRE (INSULATED): NORMAL
BRUSH HOLDER NOTCH PIN CASE

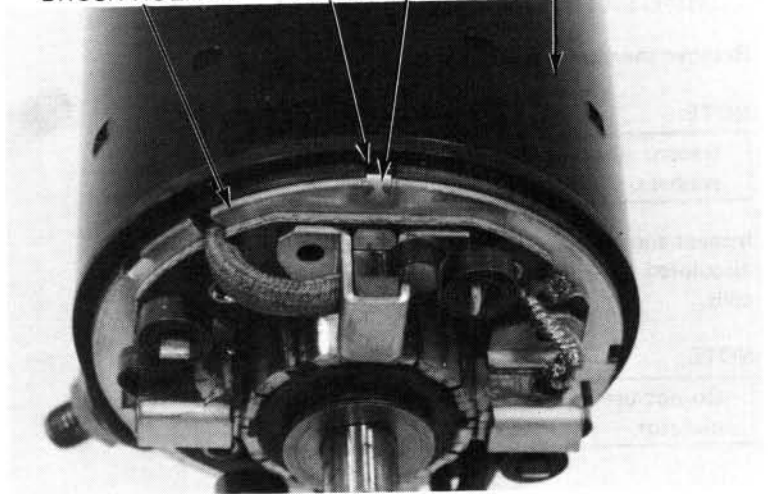

ASSEMBLY/INSTALLATION

Assemble the starter motor. Align the case notch with the brush holder pin.

Install the rear cover aligning its slot with the brush holder pin.

Install the starter motor in the reverse order of removal.

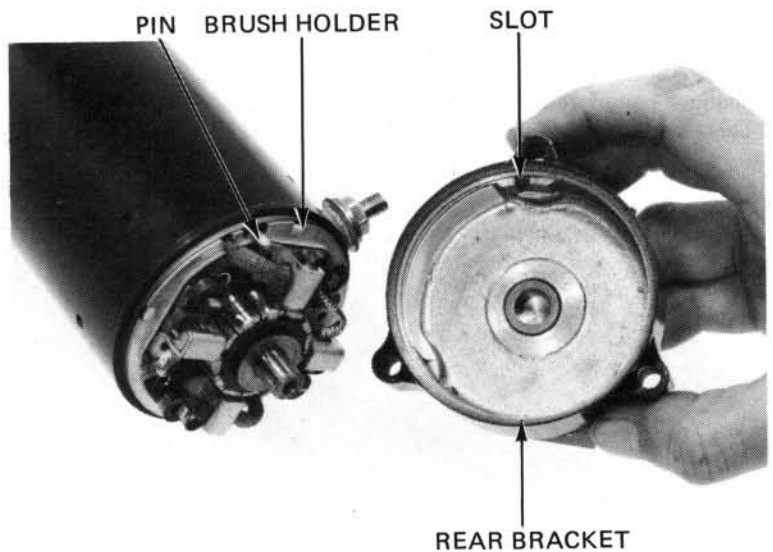

STARTER RELAY SWITCH

INSPECTION

Depress the starter switch button with the ignition ON. The coil is normal if the starter relay switch clicks.

Connect an ohmmeter to the starter relay switch terminals.

Connect a 12 V battery to the switch cable terminals. The switch is normal if there is continuity.

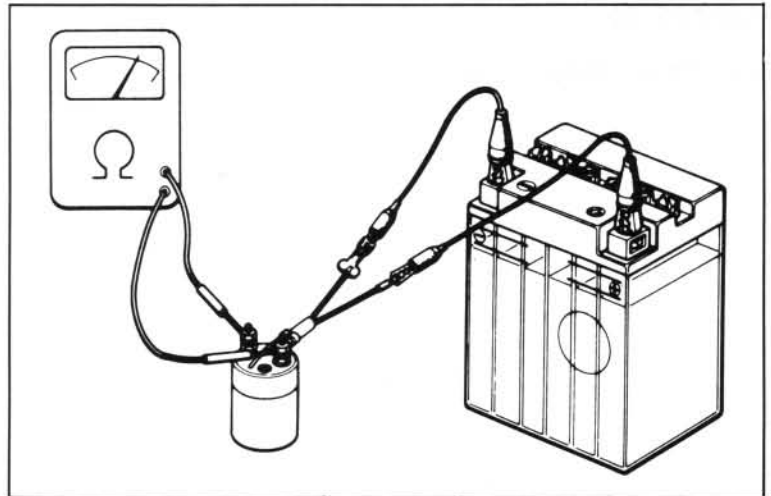

STARTER RELAY SWITCH

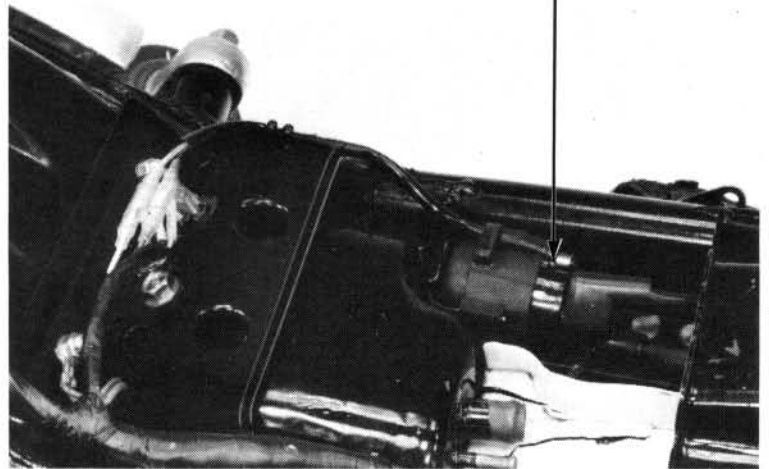

CLUTCH DIODE

REMOVAL

Remove the fuel tank.

Remove the clutch diode from the wire harness.

CLUTCH DIODE

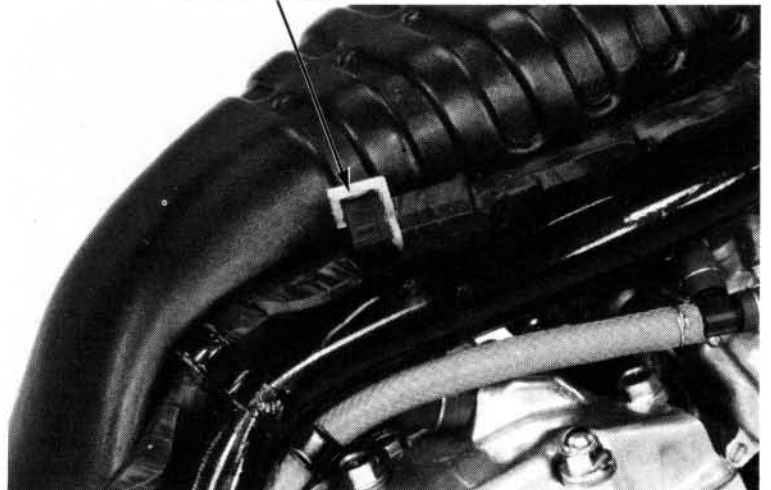

ELECTRIC STARTER

NORMAL DIRECTION: CONTINUITY
REVERSE DIRECTION: NO CONTINUITY

INSPECTION

Check for continuity with an ohmmeter.

