

LUBRICATION

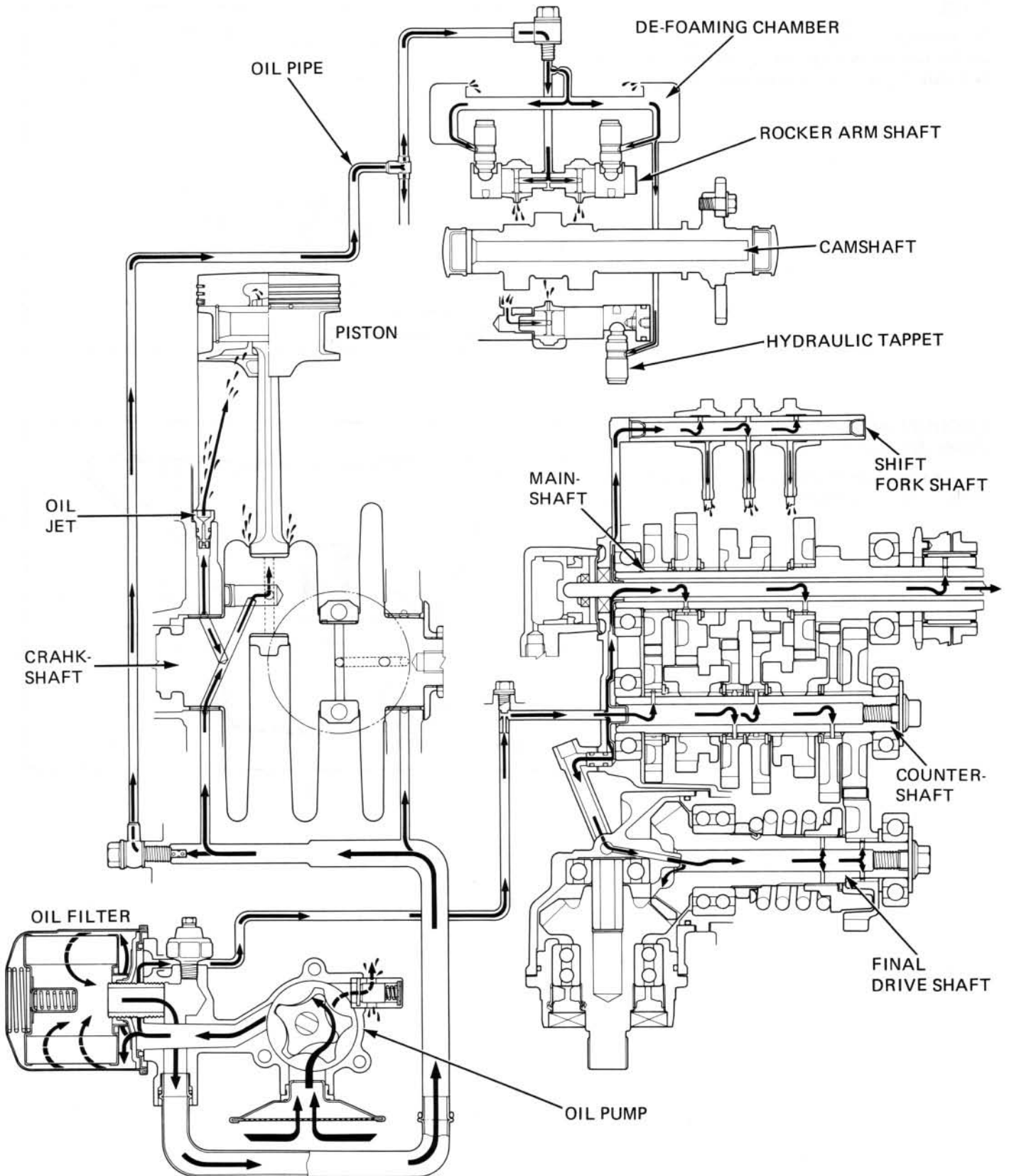

2. LUBRICATION

SERVICE INFORMATION	2-1	OIL STRAINER & OIL PUMP	2- 4
TROUBLESHOOTING	2-2	FINAL DRIVE OIL	2-11
ENGINE OIL LEVEL	2-3	CONTROL CABLE LUBRICATION	2-11
ENGINE OIL & FILTER CHANGE	2-3	LUBRICATION POINTS	2-12
OIL PRESSURE CHECK	2-4		

SERVICE INFORMATION

GENERAL

- To remove the oil pump, the following parts must be removed:
- Front cylinder exhaust pipe (Section 5).
- Right sub-frame (Section 5).
- Clutch assembly (Section 7).
- Gear shift linkage (Section 8).

SPECIFICATIONS

Engine oil

Oil capacity	3.0 liter (3.2 US qt, 2.6 Imp qt) after draining 3.5 liter (3.7 US qt, 3.1 Imp qt) after disassembly
Oil recommendation	<p>Use Honda 4-Stroke Oil or equivalent. API Service Classification: SE or SF. Viscosity: SAE 10W-40</p> <p>Other viscosities shown in the chart may be used when the average temperature in your riding area is within the indicated range.</p> <div style="text-align: right;"> <p>OIL VISCOSITIES</p> <p>The chart shows four horizontal bars representing temperature ranges for different oil grades. The top bar is SAE 20W-50, the second is SAE 20W-40, the third is SAE 10W-40, and the bottom is SAE 10W-30. The x-axis has two scales: Fahrenheit (0 to 100) and Celsius (-20 to 40).</p> </div>
Oil pressure (at oil pressure switch)	5.4 ± 0.7 kg/cm ² (62.6 ± 9.9 psi) at 6,000 rpm (80°C/176°F)
Oil pump delivery	36 liter (38.1 U.S. qt)/min. at 6,000 rpm

Oil pump service data

	STANDARD	SERVICE LIMIT
Rotor tip clearance	0.15 mm (0.006 in)	0.20 mm (0.008 in)
Pump body clearance	0.15-0.22 mm (0.006-0.009 in)	0.35 mm (0.014 in)
Pump end clearance	0.02-0.07 mm (0.001-0.003 in)	0.10 mm (0.004 in)

Final drive gear

	'83:	After '83:
Oil capacity	170 cc (5.7 oz.) after disassembly 130 cc (4.4 oz.) after draining	150 cc (5.1 oz.) after disassembly 130 cc (4.4 oz.) after draining
Recommended oil	Hypoid gear oil: Above 5°C/41°F SAE #90 Below 5°C/41°F SAE #80	Hypoid gear oil: SAE 80

LUBRICATION

TORQUE VALUES

Engine oil drain plug	30–40 N·m (3.0–4.0 kg·m, 22–29 ft·lb)
Engine oil filter	15–20 N·m (1.5–2.0 kg·m, 11–14 ft·lb)
Oil pressure switch	10–14 N·m (1.0–1.4 kg·m, 7–10 ft·lb) – Apply 3-BOND® No. 1211 or its equivalent to the bolt threads.
Oil pump	8–12 N·m (0.8–1.2 kg·m, 6–9 ft·lb)
Oil pump driven sprocket	8–12 N·m (0.8–1.2 kg·m, 6–9 ft·lb)

TOOLS

Special

Oil pressure gauge	07506–3000000	— or commercially available.
Oil pressure gauge attachment	07510–4220100	
Oil filter wrench	07912–MB00000	

TROUBLESHOOTING

Oil level too low – high oil consumption

1. External oil leaks.
2. Worn piston rings.
3. Worn valve guide or seal.

Oil contamination

1. Oil or filter not changed often enough.
2. Head gasket faulty.
3. Worn piston rings.

Low oil pressure

1. Oil level low.
2. Pressure relief valve stuck open.
3. Plugged oil pick-up screen.
4. Oil pump worn.
5. External oil leaks.

High oil pressure

1. Pressure relief valve stuck open.
2. Plugged oil filter, gallery, or metering orifice.
3. Incorrect oil being used.

No oil pressure

1. Oil level low.
2. Oil pump drive chain broken.
3. Oil pump faulty.
4. Internal oil leakage.

ENGINE OIL LEVEL

Place the motorcycle on its center stand.
Check the oil level with the filler cap/dipstick.
Do not screw it in when making this check.

If the oil level is below or near the lower level mark on the dipstick, add the recommended oil (page 2-1) up to the upper level line.

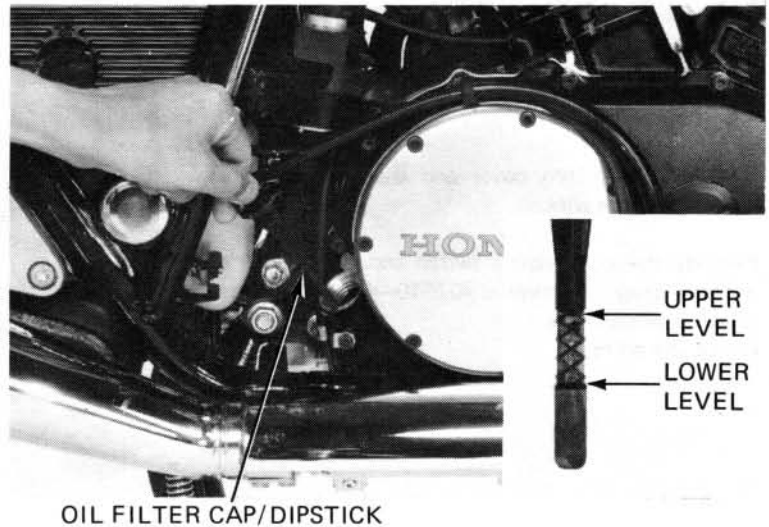

ENGINE OIL & FILTER CHANGE

NOTE:

Change engine oil with the engine warm and the motorcycle on its center stand to assure complete and rapid draining.

Remove the oil filler cap, and drain plug and drain the oil. Remove the oil filter with a filter wrench. Discard the oil filter.

Check that the sealing washer on the drain plug is in good condition and install it.

TORQUE: 30–40 N·m
(3.0–4.0 kg-m, 22–29 ft-lb)

Apply oil to the new oil filter O-ring and install the new oil filter.

Torque the oil filter with a filter wrench after placing the motorcycle on its side stand.

TORQUE: 15–20 N·m
(1.5–2.0 kg-m, 11–14 ft-lb)

After tightening the oil filter, place the motorcycle back on its center stand.

Fill the crankcase with 3.0 liters (3.2 US qt, 2.6 Imp. qt.) of the recommended oil (page 2-1).

Install the oil filler cap/dipstick.

Start the engine and let it idle for 2–3 minutes. Stop the engine and check that the oil level is at the upper level mark on the dipstick. Make sure there are no oil leaks.

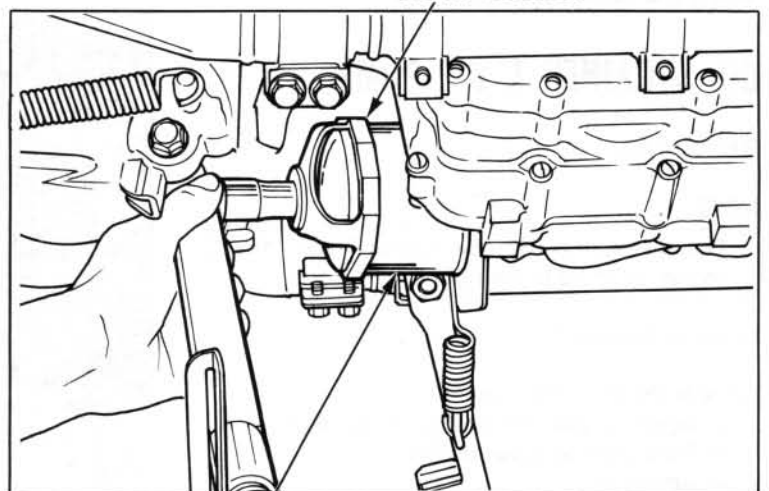
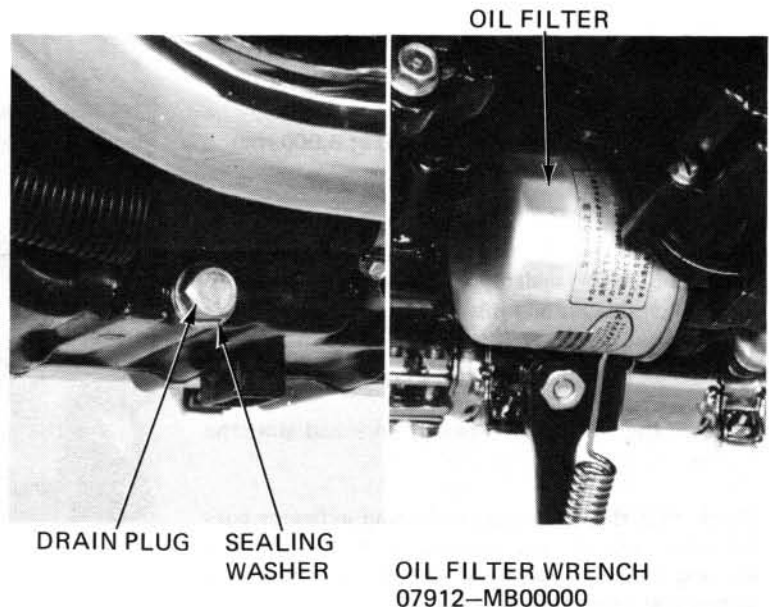

OIL FILTER
15–20 N·m (1.5–2.0 kg-m, 11–14 ft-lb)

LUBRICATION

OIL PRESSURE CHECK

Warm the engine up to normal operating temperature (approximately 80°C/176°F).
Stop the engine.

Remove the switch cover and disconnect the oil pressure switch wire.

Remove the oil pressure switch and connect an oil pressure gauge attachment (07510-4220100) to the pressure switch hole.
Check the oil level.

Start the engine and check the oil pressure at 6,000 rpm.

OIL PRESSURE:

$5.4 \pm 0.7 \text{ kg/cm}^2$ ($62.6 \pm 9.9 \text{ psi}$) at 6,000 rpm
(80°C/176°F)

Stop the engine.

Apply 3-BOND® sealant or equivalent to the pressure switch threads and install.

TORQUE: 10–14 N·m

(1.0–1.4 kg·m, 7–10 ft·lb)

Connect the oil pressure switch wire and start the engine.

Check that the oil pressure warning indicator goes out after one or two seconds. If the oil pressure warning indicator stays on, stop the engine immediately and determine the cause.

OIL STRAINER & OIL PUMP

REMOVAL

NOTE:

The oil strainer can be removed with the engine mounted in the frame.

Drain the engine oil.

Remove the following parts:

- right foot peg with the rear brake pedal.
- front cylinder exhaust pipe.
- sub-frame.
- right side cover.

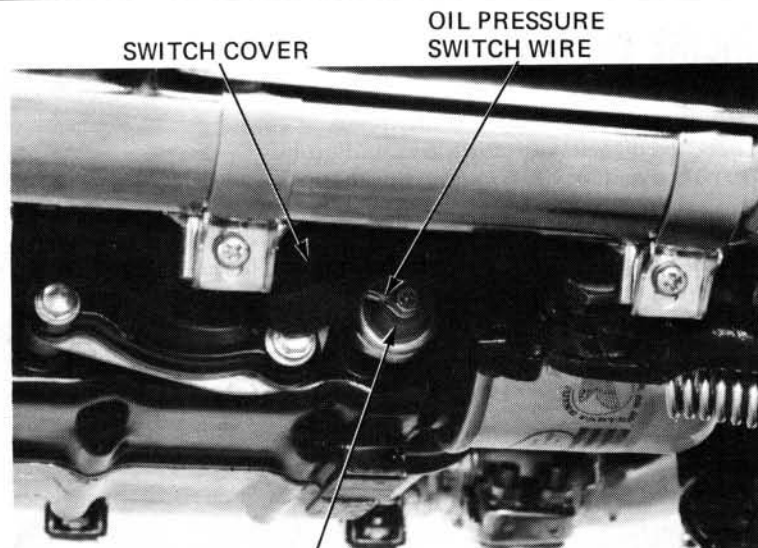

OIL PRESSURE SWITCH
OIL PRESSURE GAUGE
07506-300000 (Not available in U.S.A.)

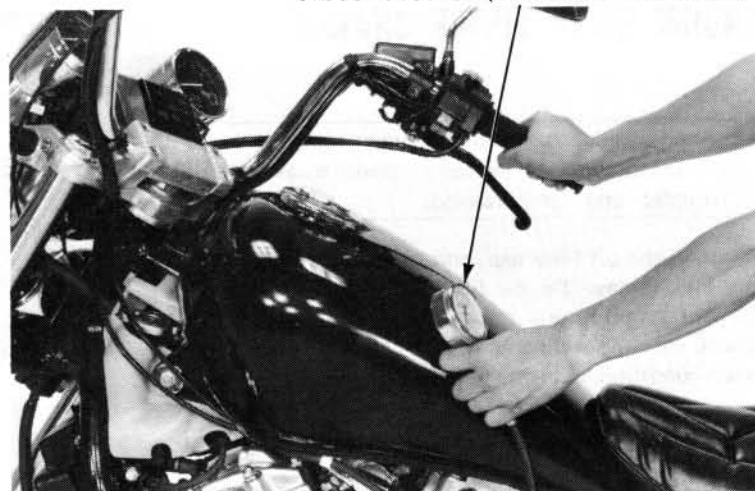

EXHAUST PIPE SUB-FRAME

Remove the following parts:

- clutch assembly (page 7-11).
- oil pump driven sprocket by removing the bolt and washer.
- gear shift linkage (page 9-2).

Pull the oil strainer downward out of the oil pump. Remove the oil pump by removing the mounting bolts and remove the oil strainer.

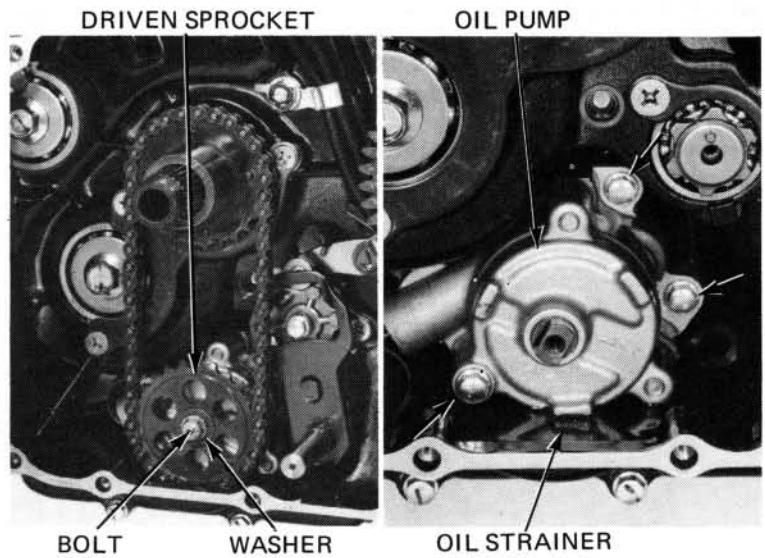

Remove the O-ring and dowel pin.

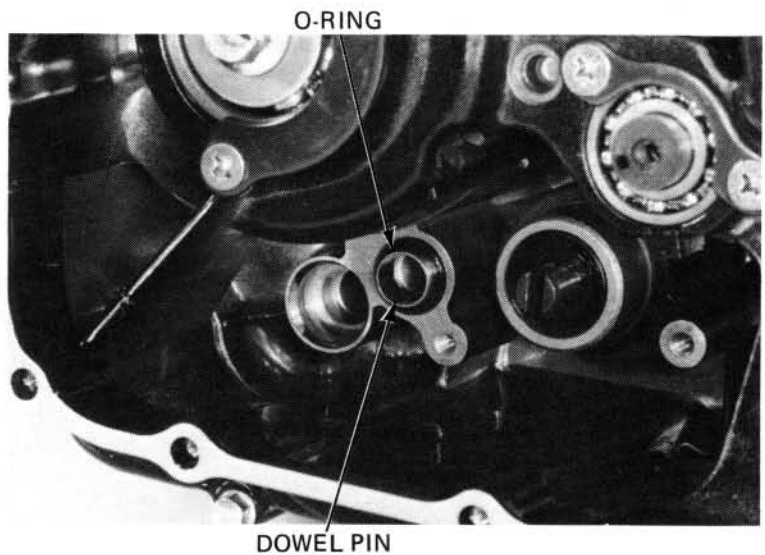

OIL STRAINER CLEANING

Clean the oil strainer with non-flammable solvent.



LUBRICATION

RELIEF VALVE CHECK

Remove the relief valve from the oil pump. Make sure the O-ring is in good condition.

Remove the relief valve snap ring and disassemble the relief valve.

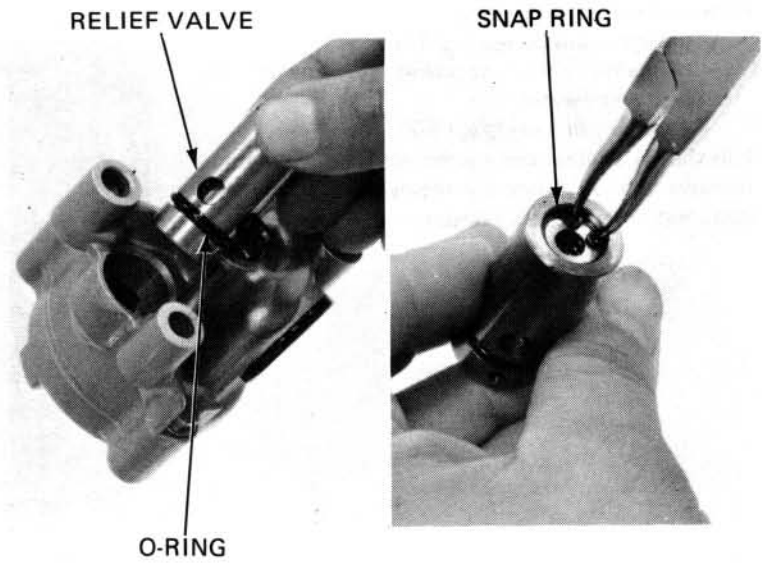

Check the spring and piston for wear or damage. Check the valve for clogging or damage. Assemble the parts in the reverse order of disassembly. Be sure to use new O-rings.

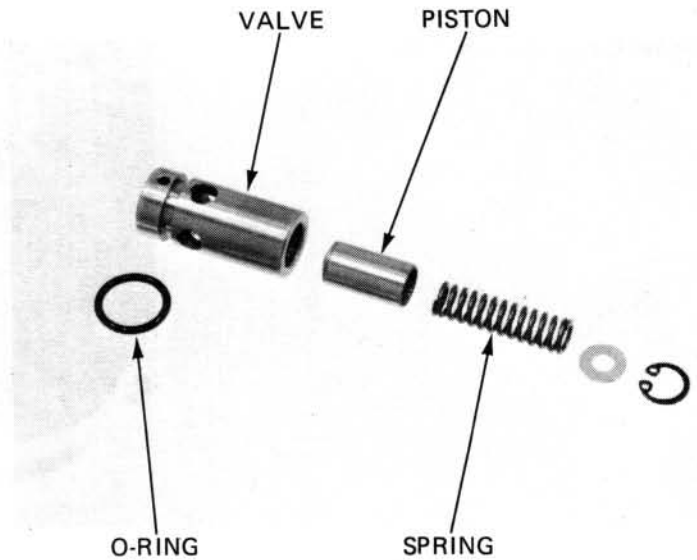

OIL PUMP DISASSEMBLY

Remove the oil pump body cover and remove the dowel pin.

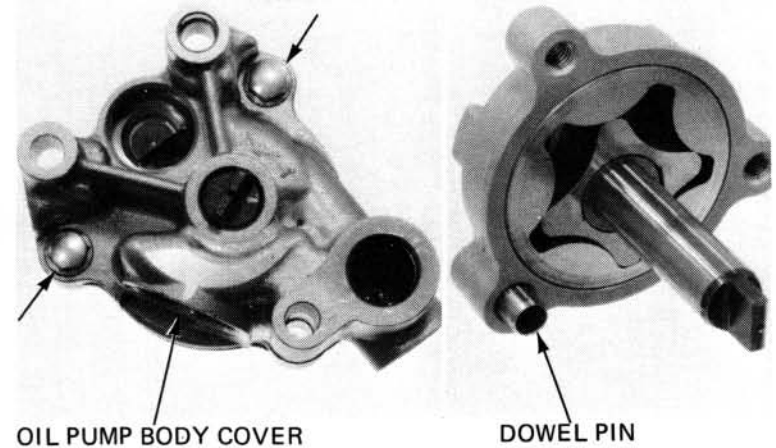

Measure the rotor tip clearance.

STANDARD: 0.15 mm (0.006 in)

SERVICE LIMIT: 0.20 mm (0.008 in)



Measure the pump body clearance.

STANDARD: 0.15–0.22 mm (0.006–0.009 in)

SERVICE LIMIT: 0.35 mm (0.014 in)



Remove the spacer and drive pin from the rotor shaft.

Remove the rotor shaft and measure the pump end clearance.

STANDARD: 0.02–0.07 mm (0.001–0.003 in)

SERVICE LIMIT: 0.10 mm (0.004 in)

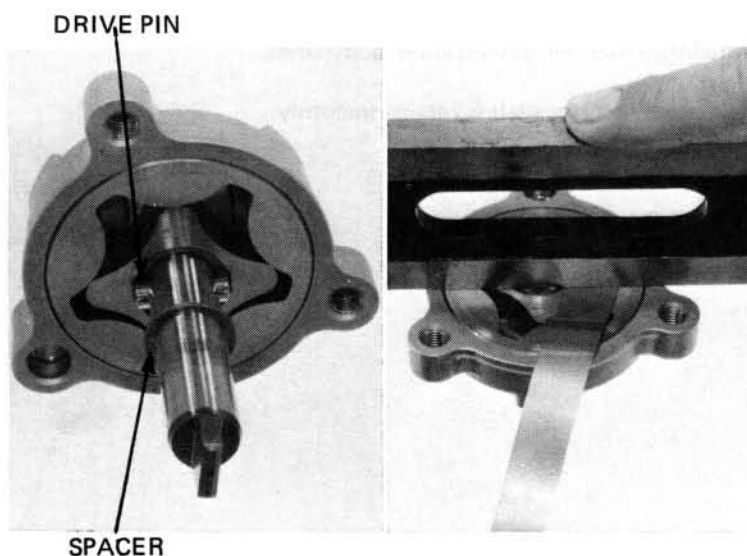

LUBRICATION

ASSEMBLY

Install the outer rotor into the body and insert the rotor shaft.

Insert the drive pin into the rotor shaft.

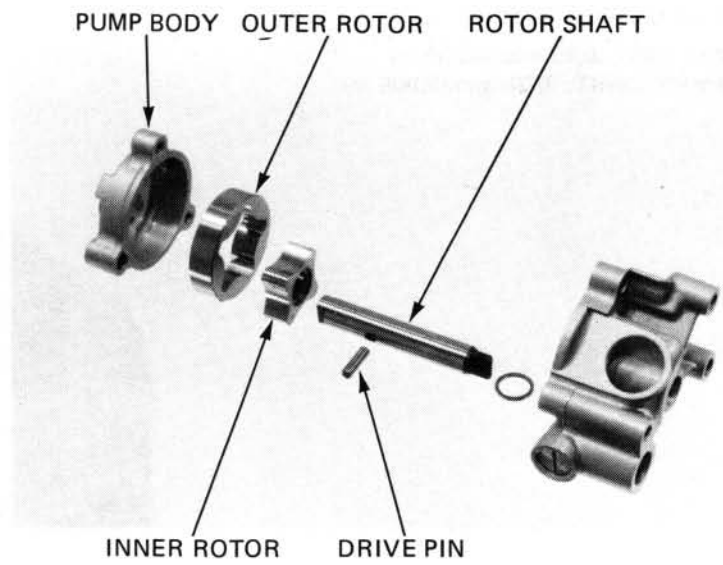

Align the slots in the inner rotor with the drive pin.

Place the spacer into the inner rotor groove.

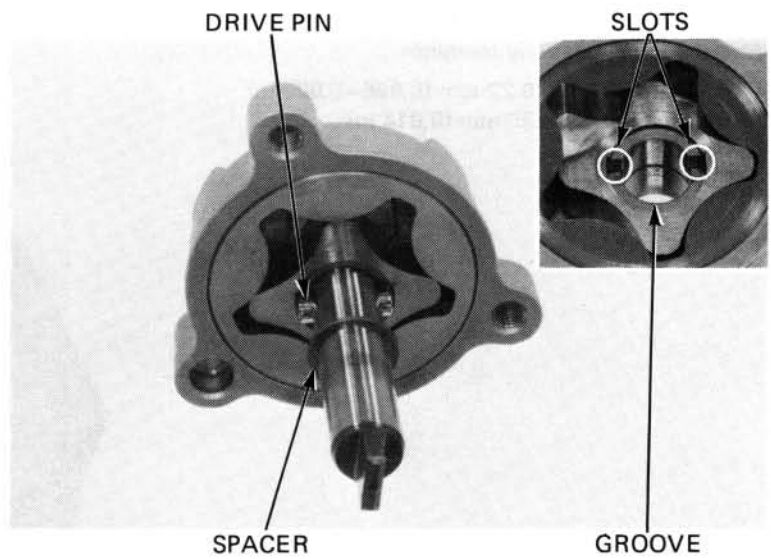

Install the dowel pin and oil pump body cover.

Make sure the rotor shaft is rotating smoothly.

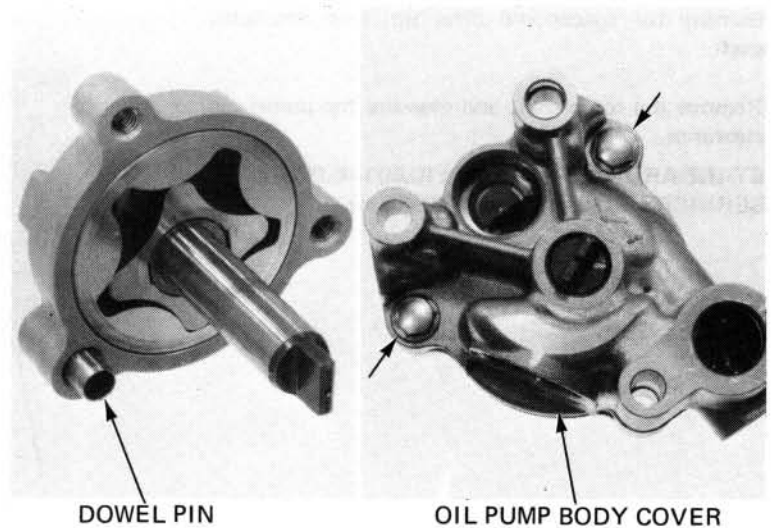

Install the relief valve with a new O-ring into the oil pump body.

Install a new O-ring into the oil strainer hole.

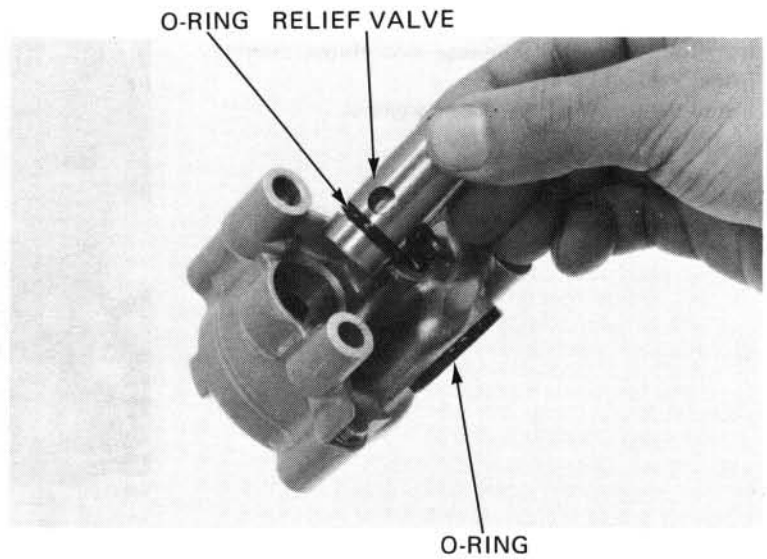

INSTALLATION

Install the dowel pin and a new O-ring.

Put the oil strainer into the crankcase, and then install the oil pump. Tighten the bolts.

TORQUE: 8–12 N·m
(0.8–1.2 kg-m, 6–9 ft-lb)

Install the oil strainer.

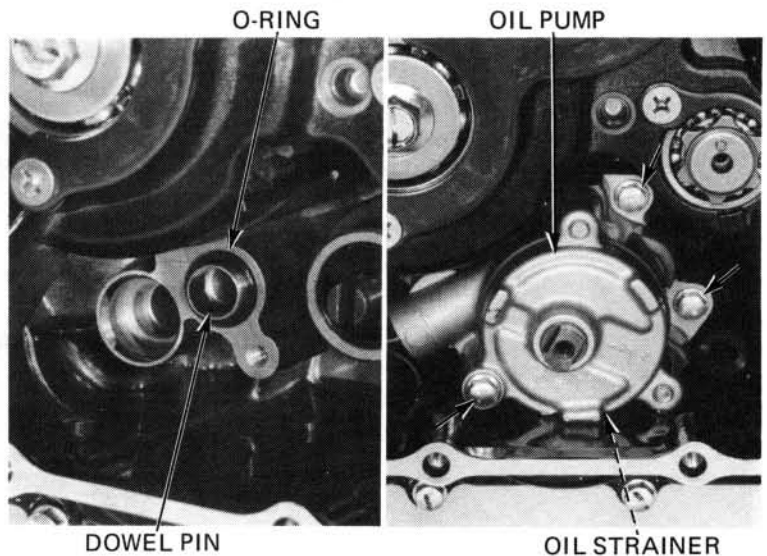

Place the oil pump driven sprocket into the drive chain. The "IN" mark on the driven sprocket should face the crankcase.

Install the washer and tighten the bolt.

TORQUE: 8–12 N·m
(0.8–1.2 kg-m, 6–9 ft-lb)

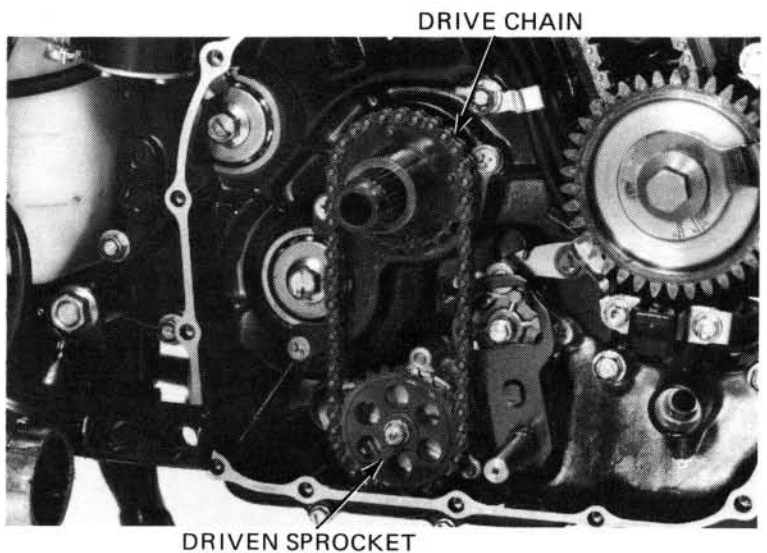

LUBRICATION

Install the gear shift linkage and clutch assembly (pages 7-17 and 9-4).

Install the dowel pins and a new gasket.

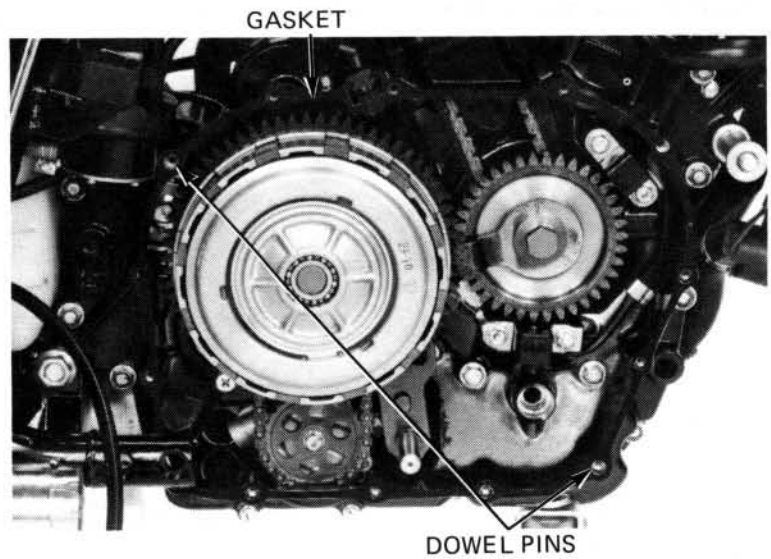

Install the following parts:

- right side cover.
- right sub-frame.
- front cylinder exhaust pipe.
- right foot peg with the rear brake pedal.

Fill the engine with the recommended oil (page 2-3).

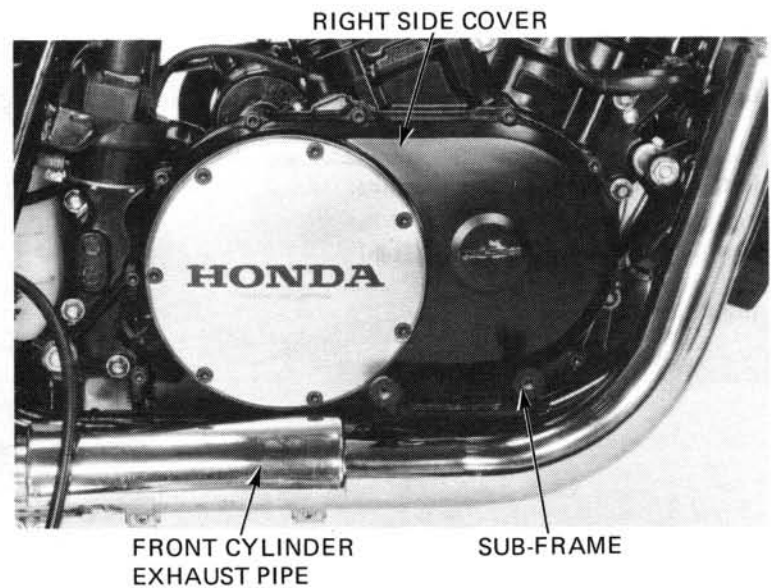

FINAL DRIVE OIL

CHECK

Place the motorcycle on its center stand on level ground.

Remove the oil filler cap.

Check that the oil level reaches the lower edge of the oil filler cap hole.

Check for leaks, if the level is low. Pour fresh oil through the oil filler hole until it reaches the lower edge.

CHANGE

Remove the oil filler cap and drain bolt to drain all oil from the final gear case.

Install the drain bolt securely.

Fill the gear case with the recommended oil up to the correct level (above).

OIL CAPACITY: 130 cc (4.4 oz)

RECOMMENDED OIL:

'83:

HYPOID GEAR OIL API,

GL-5 SAE #90 (Above 5°C/41°F)

SAE #80 (Below 5°C/41°F)

After '83:

HYPOID GEAR OIL: SAE #80

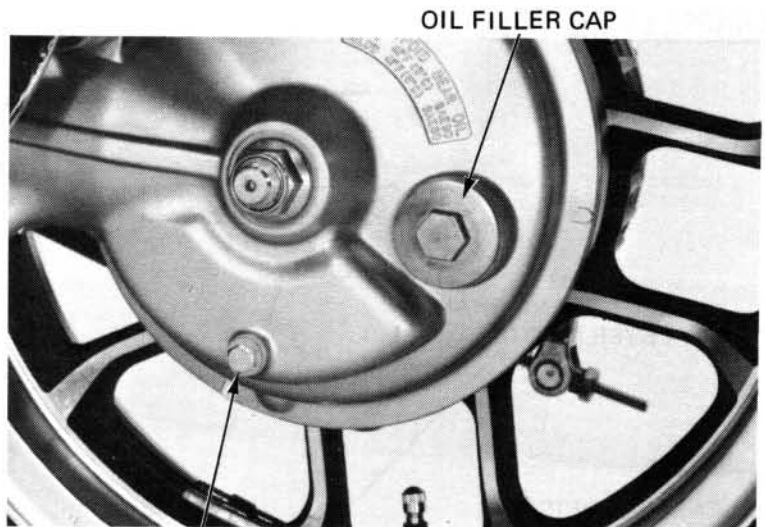

OIL FILLER CAP

OIL DRAIN BOLT

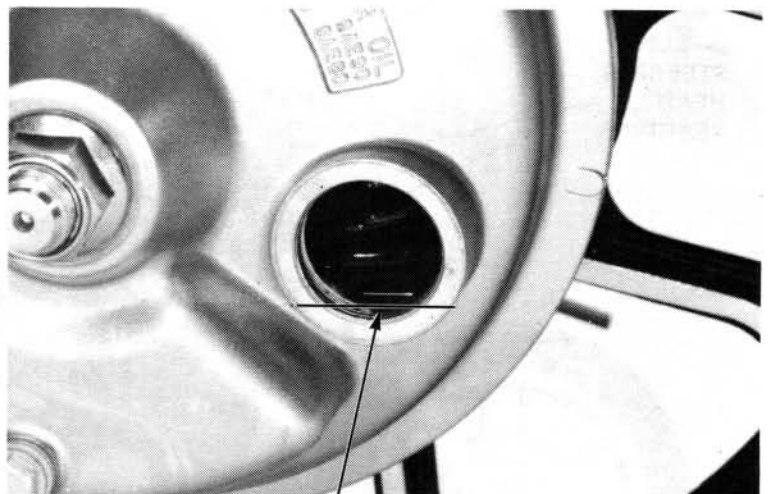

OIL LEVEL

CONTROL CABLE LUBRICATION

Periodically, disconnect the throttle cables at their upper ends. Thoroughly lubricate the cables and their pivot points with a commercially available cable lubricant or a light weight oil.

LUBRICATION

LUBRICATION POINTS

